

Date: June 25, 2021

RE: Village Hall and Site Construction, EN2104 & EN2105– Request for information

Thank you for your interest in the Village's project. Highlighted responses to requests for information are listed below. Please note the list is a compilation of questions submitted from multiple Contractors and Suppliers.

Previous RFI responses and addenda can be viewed at: <http://www.royalpalmbeach.com/rfps>

Sincerely,

Christopher Marsh, P.E.
Village Engineer
Office: (561) 791-7092
Village of Royal Palm Beach
Engineering Department
1050 Royal Palm Beach Boulevard
Royal Palm Beach, FL 33411
cmarsh@royalpalmbeach.com

From: Mark Deiana <mark@wischandjackson.com>
Sent: Wednesday, June 23, 2021 1:26 PM
To: Robin Cronk <RCronk@RoyalPalmBeach.com>
Subject: RE: RFI for Village Hall and Site Construction

The Village will be issuing an Addendum to address the items noted below:

R-26

RFI #1

Specification section 230923: Page13 Item D states the following:

"Control system shall include the following:

- Building intrusion detection system specified in Section 281600 "Intrusion Detection."
- Building clock control system specified in Section 275313 "Clock Systems."
- Building lighting control system specified in Section 260943.13 "Addressable-Fixture Lighting Controls" and Section 260943.23 "Relay-Based Lighting Controls."
- Fire alarm system specified in Section 283111 "Digital, Addressable Fire-Alarm System" and Section 283112 "Zoned (DC Loop) Fire-Alarm System."

Are these systems to be included by the BMS contractor?

Those items are not required in the BAS system. An addendum will be issued to remove the items from the specifications.

R-25

RFI #2

Specification section 230923: Page 16 Item D:2 states the following:

[Sustainability Kiosk Option] Sustainability Kiosks. Contractor shall furnish two (2) computers with touchscreen monitors that meet or exceed the following requirements:

- 2.33 GHz or faster x86 compatible processor
- 2 GB RAM
- 500 GB Hard Drive

- 27 inch [Insert screen size from Operator Interface General Question] or larger LED touchscreen monitor with 1920 x 1080 (minimum) full HD resolution and 16:9 aspect ratio.

Are Sustainability Kiosk's required for this project? If so, where are they to be located?

Contractor is not required to provide sustainability kiosks. An addendum will be issued to remove the items from the specifications.

R-24

RFI #3

Q. The contract documents reference an open BACnet connection to VFD's. Please confirm that there will indeed be VFD's? The industry has been providing ECM motors hence there is no VFD for integration.

VFD's are required.

From: Phyllis Rarus <PRarus@worlddryer.com>

Sent: Tuesday, June 22, 2021 9:36 AM

To: Vickie Day <vday@RoyalPalmBeach.com>

Subject: Royal Palm Beach Village Hall

R-23

Q. One is from the architectural drawings A-4.20 which shows paper towels (specifically room 111 as an example). The electrical panel E-504 shows hand dryers (also room 111). Can someone let me know if hand dryers or paper towels are required for this project. If hand dryers are required, than what model are they looking for.

The electrical plans include a circuit and wiring for electric hand dryers in all restrooms to allow paper towel dispensers to be changed to electric hand dryers in the future. The only restrooms that will receive electric hand dryers are 119, 121, and 122 as detailed in the architectural drawings. All other restrooms will receive paper towel dispensers (electrical box centered behind the dispenser for a future electric hand dryer) as detailed in the architectural plans. An addendum will be issued to update the architectural plans.

From: Brandi Flanagan <brandi.flanagan@construction.com>

Sent: Monday, June 21, 2021 2:53 PM

To: Vickie Day <vday@RoyalPalmBeach.com>; Christopher Marsh <CMarsh@RoyalPalmBeach.com>

Subject: Village Hall and Site Construction

R-22

Q. Can you tell me where to find additional/detailed info on the Green Wall, details of the circled area in drawing A-4.50? it is the one with the section: 4 Main Lobby (127) Elevation 3

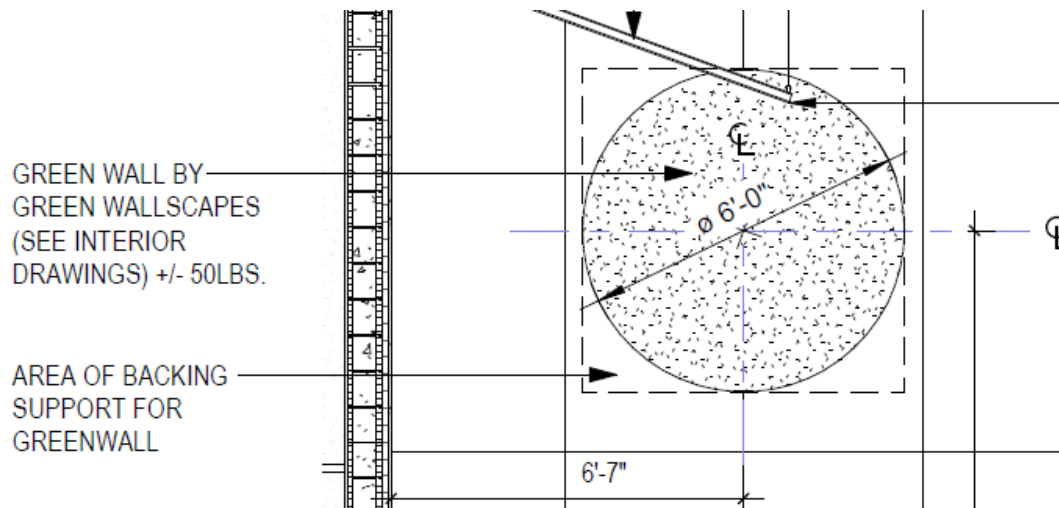



As stated in the drawings, the green wall feature is provided by Green Wallscapes. These items are all custom made by the company for the customer as an "art" piece. Our Interior Designer contacted the company and obtained the below quote for informational purposes. It is a 6'-0" diameter preserved moss and fern, circled-shape installation. The attached document does not constitute the final price for the item, it was obtained for informational purposes. The final piece may vary slightly in appearance from that shown in the attached picture. Bidders must contact Green Wallscapes (contact information attached in quote) for additional information regarding delivery and installation of item. Drawings call for backing behind wall in this location as we were informed that the piece can weigh up to 50 lbs.



QUOTE NUMBER 1679 DATE June 21, 2021 VALID UNTIL October 19, 2021 at 3:43PM	FROM Lindsay Scherr Burgess Green Wallscapes 1177 Clare Ave STE 7 West Palm Beach, FL 33401 GreenWallscapes.com PHONE 561-877-3100	FOR REG Architects TO Veronica Volani-Inza
--	--	---

Village Hall of Royal Palm Beach - 6' Diameter Circle

6' Diameter Preserved Moss and Fern Circle Like, below, no branches   Main Lobby Int Elevation at GreenWall	185.00 x 29 5,365.00
---	----------------------------

From: Al Ziri <al.ziri@kvconstructors.com>
Sent: Thursday, June 17, 2021 3:32 PM
To: Christopher Marsh <CMarsh@RoyalPalmBeach.com>
Subject: RPB Village Hall

The Village will be issuing an Addendum to address the items noted below:

Q / A	Reference	Description	
R-21	Q1	A-6.10	Door 116: Advise hardware requirements
	A1		Door 116 shall be equipped with Hardware Group #6. Change will be made in the drawings.
R-20	Q2	A-6.10	Hardware Set 2: Calls for hardware for Pair doors. It states for Rim Exit Device & Cylindrical Lock – if Exit devices required must change to Surface Vertical Rod on both leave. Please clarify. Do they want access from outside with key? Please advise
	A2		Hardware Set 2 is for both single and pairs of hollow metal doors. Hardware Group #2 references RD-2 Rim Exit Device. Specification 087100 – 2.6 A reference Rim Exit Device as Von Duprin 98/99 Series. The use of “Surface Vertical Rod” option within the 98/99 Series is acceptable for the double doors in this group. Hardware group specifies storeroom lever lockset to provide keyed access and security from outside.
R-19	Q3	A-6.10	Hardware Set 3: They call for Exit Device and Cyl. Lock on the same door – Please clarify. Specified El strike is not NOA approved – please correct
	A3		Electric Strike will be removed from exterior access controlled doors. Added note in Specifications and drawings to provide manufacturer’s standard “electrified” option on Exit Devices. Suggest Von Duprin QEL option.
R-18	Q4	A-6.10	Hardware Set 7: States for Passage set and Push Pulls – it one or the other Please advise It also calls for key cylinder (KC-1) do they want Deadbolt or advise
	A4		Correct hardware is push/pull. Passage set will be deleted from drawings. Intent is to have keyed cylinder so restrooms doors can be locked from the outside if needed, but need to allow egress
R-17	Q5	A-6.10	Hardware Set 9: They state for Exit Device and Cyl. Lock on the same door – Please clarify In addition the doors with this set are Pair doors: It calls for Rim Exit Device & Cylindrical Lock – if Exit devices required must change to Surface Vertical Rod on both leave. Please clarify
	A5		Hardware Group #9 references RD-2 Rim Exit Device. Specification 087100 – 2.6 A reference Rim Exit Device as Von Duprin 98/99 Series. The use of “Concealed Vertical Rod” (not surface) option within the 98/99 Series is acceptable for the double doors in this group. Door are meant to have a keyed level lockset on the non-egress side to allow for doors to be locked from the non-egress side.

From: Leah Griffin <lgriffin@statecontracting.com>
Sent: Friday, June 18, 2021 9:35 AM
To: Christopher Marsh <CMarsh@RoyalPalmBeach.com>
Cc: Vickie Day <vday@RoyalPalmBeach.com>; Adrian Viera <aviera@statecontracting.com>
Subject: SCEC RFI 06 - Village Hall Construction EN2104 & EN2105

- R-16
1. The Bid Form (BF-27) has a calendar days duration of 180 days for Phase II Substantial Completion while the Contract (C-41) has a calendar days duration of 150 days. Please confirm which governs.

The calendar days duration is 180 days. The Village will issue an Addendum updating page C-41. An Addendum will be issued to remove the conflict in the contract.

From: Leah Griffin <lgriffin@statecontracting.com>
Sent: Thursday, June 17, 2021 11:57 AM
To: Christopher Marsh <CMarsh@RoyalPalmBeach.com>

Cc: Vickie Day <vday@RoyalPalmBeach.com>; Adrian Viera <aviera@statecontracting.com>

Subject: SCEC RFI 05 - Village Hall Construction EN2104 & EN2105

Acknowledging that a new Clean Agent System is to be provided in the new server room, and regarding Specification Section 212200 Clean-Agent Fire-Extinguishing Systems:

R-15

1. Under Part 2.2, Letter K, please confirm this project requires remote air-sampling detector system.

The remote air-sampling detector system will not be required.

R-14

2. Under Part 2.2, Letter N, please confirm EPO shutdown configuration is required.

Yes, confirmed

R-13

3. Under Part 2.2, Letter P, please confirm Power Transfer Switch is required.

Yes, confirmed, this will be provided in Fire-Trace panel

R-12

4. Under Part 2.9, Letter F, please confirm graphic Annunciator Panel is to be provided as specified.

Yes, confirmed, this will be provided in Fire-Trace panel

From: Leah Griffin <lgriffin@statecontracting.com>

Sent: Wednesday, June 16, 2021 10:34 AM

To: Christopher Marsh <CMarsh@RoyalPalmBeach.com>

Cc: Vickie Day <vday@RoyalPalmBeach.com>; Adrian Viera <aviera@statecontracting.com>

Subject: SCEC RFI 04 - Village Hall Construction EN2104 & EN2105

R-11

1. Please clarify if the scope of work for the Sheriff Building and Farber-Training Building should be done during Phase 1 or Phase 2 of the project.

The work for the Sheriff Building and Farber Training Building shall be completed during Phase 1.

From: Al Ziri <al.ziri@kvconstructors.com>

Sent: Monday, June 14, 2021 10:47 AM

To: Christopher Marsh <CMarsh@RoyalPalmBeach.com>

Subject: RPB Village Hall

*The Village will be issuing an Addendum to address the conflicting language in the plans and Bid Documents as noted below: **ADDENDUM FOUR ISSUED 6/16/2021***

R-10

Q / A	Reference	Description
Q1	General	Is there a geotech soils report available?
A1		<i>Yes, an addendum will be issued to add this report</i>
Q2	General	Is there a survey plan showing existing elevations? Current plans do not show any.
A2		<i>Yes, an addendum will be issued to add the existing survey</i>
Q3	Specs	Division 08: YKK & Viracon are the specified products. Can we provide equivalent products?
A3		<i>Both YKK & Viracon are listed as the Basis of Design in the project. As stated in spec section 016000, 2.1 B 7: approval of product by unnamed manufactures shall comply with the requirements of Section 012500 for a Substitution of Convenience. Product information would have to be submitted for review and approval by Architect and Owner.</i>

R-7

	Q4	A-0.10	5/8" drywall is mentioned for partitions throughout however specs section calls for 1/2" drywall at ceilings. Please confirm.
R-7	A4		<ul style="list-style-type: none"> • 5/8" drywall is for wall assemblies as noted in Spec Section 092900, 2.3 B and concurrently in the wall type schedules (sheet A-0.10). • 1/2" drywall is for ceiling assemblies as noted in Spec Section 092900, 2.3 D. • The only instance where 5/8" drywall may need to be used in drywall ceilings is when required for fire-rated ceilings assemblies (UL or AER).
	Q5	A-0.10	General notes 33 states that contractor is to employ a material testing company. Specs section 01400, 1.8 A and also section 03300, 2.2A states that it is the Owner responsibility. Please clarify.
	A5		<p>Section 01400, 1.8 A notes Owner's responsibilities, <u>should</u> the Owner be responsible for certain quality control services, it does <u>NOT</u> explicitly indicate which of these services are the responsibility of the Owner vs. Contractor, those are stated in individual specification sections as required.</p> <p>Section 01400, 1.8 B notes that test and inspections not explicitly assigned to the Owner are the Contractor's responsibility.</p> <p>As a default, the Contractor will be responsible for engaging the services of all testing agencies.</p> <p>Specification Sections that may conflict will be modified via addendum.</p>
R-5	Q6	S-1.00	F90 footing not in schedule but shown in floor plan.
	A6		An addendum will be issued for the following. Footing added to footing schedule on S-2.
R-4	Q7	S-3.00	TB-6 and B-17 as shown on detail 6 do not match the size shown in beam schedule.
	A7		An addendum will be issued for the following. TB-6 reinforcement revised in schedule on S-2. Section 6 on S-3 beam size revised to match beam schedule

From: Leah Griffin <lgriffin@statecontracting.com>
Sent: Friday, June 11, 2021 3:21 PM
To: Christopher Marsh <CMarsh@RoyalPalmBeach.com>
Cc: Vickie Day <vday@RoyalPalmBeach.com>; Adrian Viera <aviera@statecontracting.com>
Subject: SCEC RFI 03 - Village Hall Construction EN2104 & EN2105

- R-3
1. Sheet E-401 refers to Panels ACA, ACB, ACC & ACD. Panel Schedules for those Panels do not appear to be included on the drawings. Please clarify or provide Panel Schedules.

Addendum Three was issued on 6/11/2021 which was revised plan page FP-102 to address this correction.

Panel schedule sheets that contained those schedules were not issued. The Village will be issuing an Addendum to add the drawing sheets.

From: Leah Griffin <lgriffin@statecontracting.com>
Sent: Tuesday, June 8, 2021 10:01 AM
To: Christopher Marsh <CMarsh@RoyalPalmBeach.com>

Cc: Vickie Day <vday@RoyalPalmBeach.com>; Adrian Viera <aviera@statecontracting.com>

Subject: RFI - Village Hall Construction EN2104 & EN2105

R-2

1. As per Specification 28311, the fire alarm system is to match the existing onsite campus system. Please provide the name of the existing manufacturer and most current certifier.

Honeywell Fire-Lite panels are at the existing Village Hall complex.

Our current fire alarm monitoring company:

Chris Cisco

1st Fire & Security

610 1st St.

Vero Beach, FL 32962

Ph: (772) 794-2220

Fax: (772) 794-2204

From: Leah Griffin <lgriffin@statecontracting.com>

Sent: Tuesday, June 8, 2021 10:43 AM

To: Christopher Marsh <CMarsh@RoyalPalmBeach.com>

Cc: Vickie Day <vday@RoyalPalmBeach.com>; Adrian Viera <aviera@statecontracting.com>

Subject: RFI - Village Hall Construction EN2104 & EN2105

R-1

1. On FP-102 Server Rm 214 the notes say to "relocate clean agent bottle & piping from existing Server Rm...". Please confirm if an analysis of the existing room volume versus the new room volume aligns with a tank size need that matches the existing tank being called out for relocation. As a prudent suggestion, an entire new Clean Agent System should be provided at the new Server Room.

An entire new Clean Agent System will be provided in the new Server Room. Specification for the new system is called out in the FP drawings. The Village will be issuing an Addendum to address the conflicting language in the plans. ADDENDUM THREE ISSUED 6/11/2021